

# MC3336 Wiring Diagram

Model: 776231-1

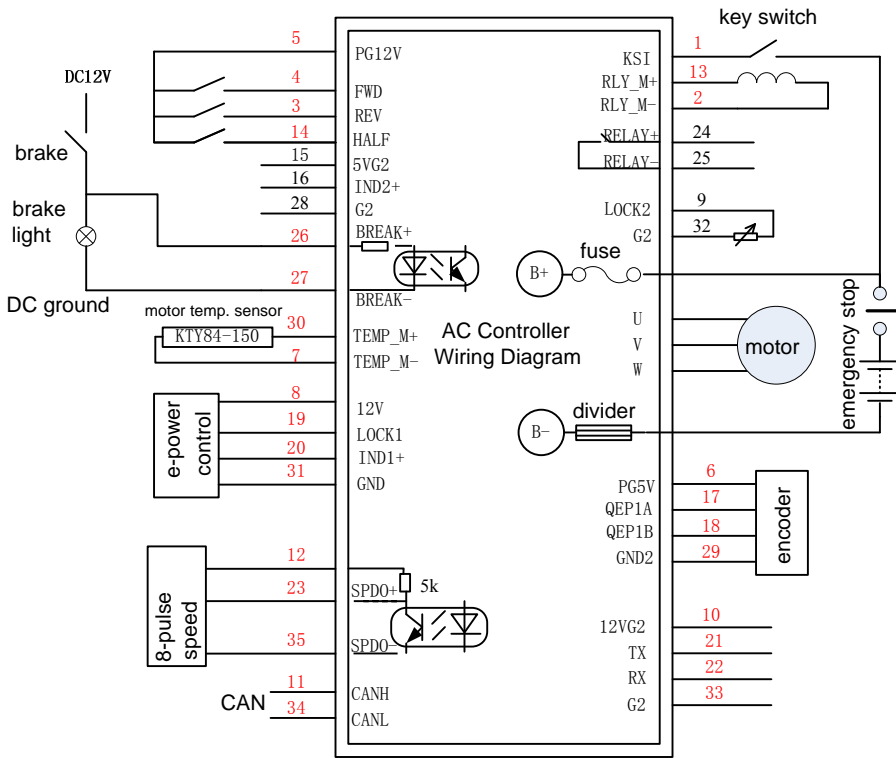

- J1.1 - purple: key switch (KSIF)
- J1.8 - red: accelerator power supply "+" (12V)
- J1.19 - yellow: accelerator switch (LOCK 1)
- J1.20 - green: accelerator signal (IND1 +)
- J1.31 - black: accelerator power supply "-" (GND)
- J1.5 - red: key switch power supply "+" (PG12V)
- J1.4 - blue: forward signal wire (FWD)
- J1.3 - brown: backward signal wire (REV)
- J1.14 - white: high/low speed mode (HALF)
- J1.11 - red: CANH
- J1.34 - black: CANL
- J1.6 - purple: encoder power supply "+" (PG5V)
- J1.29 - grey: encoder power supply "-" (GND2)
- J1.17 - pink: encoder A signal (QEP1A)
- J1.18 - brown: encoder B signal (QEP1B)
- J1.30 - white: motor temperature resistance (TEMP\_M+)
- J1.7 - white: motor temperature resistance (TEMP\_M-)
- J1.12 - red: dashboard power supply "+"
- J1.23 - yellow: dashboard speed test signal (SPD0+)
- J1.35 - black: dashboard power supply "-" (SPD0-)
- J1.26 - orange: brake signal (BREAK +)
- J1.27 - green: car DC ground (break -)

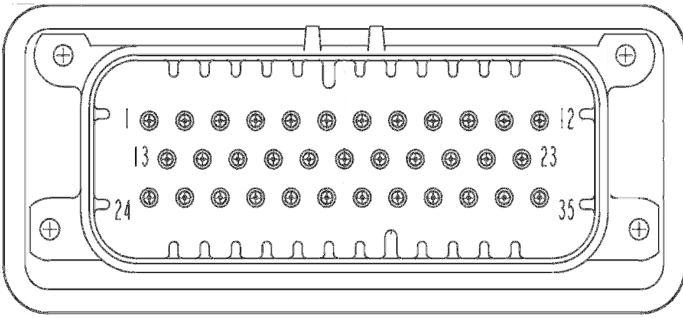